

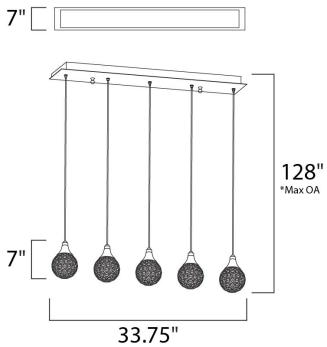

PRODUCT DESCRIPTION

With formed metal spheres of Polished Chrome framing multifaceted crystal jewelry, the Brilliant Collection adds a touch of contemporary elegance to any design space. The illumination of xenon lamps reflecting through the crystal offers added brilliance by creating a spectrum of color.



*max overall height

MEASUREMENTS

DIMENSION : 33.75" L x 7" W x 7" H
 MAX OAH : 128" OAH
 HANGING WEIGHT : 8.84 lb

LAMPING

INPUT VOLTAGE : 120V
 LUMENS : 2,500 Rated
 BULB : 5 x 40W Xenon G9 , 200W Total
 BULB INCLUDED : (Included)
 DIMMABLE : Yes
 COLOR_TEMP : 2900K

FINISHES OPTION

 Polished Chrome (PC)

GLASS

Crystal 20

MATERIAL

Steel, Crystal

RATINGS

cETLus
 Dry Location



ADDITIONAL

RATED LIFE 2000 Hours
 OPERATING TEMPERATURE:
 -20°C (-4°F), 40°C (104°F)

Always consult a qualified electrician before installing any lighting product.



WESTERN DISTRIBUTION CENTER (HEADQUARTER)
 253 NORTH VINELAND AVE | CITY OF INDUSTRY, CA 91746
 EASTERN DISTRIBUTION CENTER
 101 GARDNER PARK | PEACHTREE CITY, GA 30269
 P. 626.956.4200 | F. 626.956.4225 | maximlighting.com