

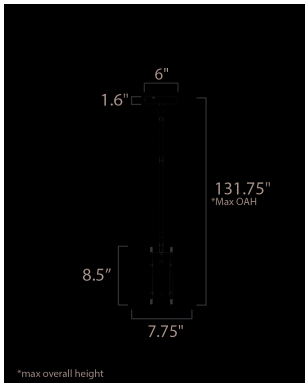

PRODUCT DESCRIPTION

Three sizes stainless steel intersecting panels in ellipses and spheres are illuminated by a double raceway of dedicated LED light strips. An additional LED light source directs light downward. Stylishly finished in brushed Satin Brass or Matte Black, these sculptural lighting elements complement an architectural environment adding interest and functional light.





MEASUREMENTS

DIMENSION : 7.75" L x 7.75" W x 8.25" H
 MAX OAH : 53.25" OAH
 CANOPY : 6" W x 1.6" H x 6" L
 HANGING WEIGHT : 7.5 lb

LAMPING

INPUT VOLTAGE : 120V
 LUMENS : 1,260 Rated (900 Del.)
 BULB : 1 x 18W LED PCB Integrated , 18W Total
 BULB INCLUDED : (Integrated)
 DIMMABLE : Triac
 CRI : 90 CRI
 COLOR_TEMP : 3000K

FINISHES OPTION

-  Black (BK)
-  Satin Brass (SBR)

MATERIAL

Aluminum + Steel + Acrylic

RATINGS

cETLus
 Dry Location



ADDITIONAL

SLOPE: 70
 RATED LIFE 40000 Hours
 OPERATING TEMPERATURE:
 -20°C (-4°F), 40°C (104°F)

Always consult a qualified electrician before installing any lighting product.



WESTERN DISTRIBUTION CENTER (HEADQUARTER)
 253 NORTH VINELAND AVE | CITY OF INDUSTRY, CA 91746
 EASTERN DISTRIBUTION CENTER
 101 GARDNER PARK | PEACHTREE CITY, GA 30269
 P. 626.956.4200 | F. 626.956.4225 | maxlighting.com